

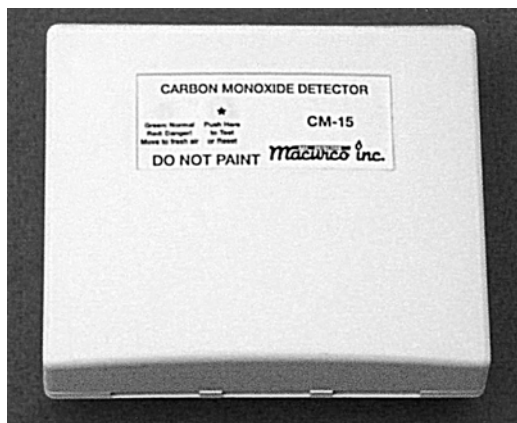

Carbon Monoxide Detector

FOR USE WITH ALARM CONTROL PANELS



CM-15/15A

- SPDT alarm relay
- LED for operating status
- 12-24 VDC / 13-24 VAC Input
- Flush or surface mount
- Long life sensor
- All units individually calibrated

FEATURES

- **Listed to UL Standard 2075** for carbon monoxide detectors.
- **Tested to UL Standard 2034** for carbon monoxide detectors.
- Surface mounts to a wall over a single gang electrical box.
- Flush mounts to the wall over a 4 X 4 or two gang electrical box.
- Small, low profile, attractive unit in a white plastic case. It looks similar to a thermostat.
- Detector alarms at multiple levels of exposure to **carbon monoxide** based on time weighted averages of the gas present.
- Inexpensive, easy to install. Microcomputer control allows mostly automatic operation.
- Test & Reset switch conducts internal tests and actuates relays.
- Visual display: **GREEN** - Normal operation.
FLASHING AMBER - Trouble Contact your installer or Macurco Tech Support
RED - Danger! Move to fresh air (hazardous condition is present.)
- **Solid state sensor.** No maintenance or periodic sensor replacement needed.
- **SPDT Relay** to connect to Alarm Control Panels or switch external alarm devices.
- Normally closed SPST Trouble relay provides means for **system-wide supervision.**

CONFIGURATIONS

CM-15
 SPDT Alarm Relay
 SPST Trouble Relay

CM-15A
 SPDT Alarm Relay
 SPST Trouble Relay
 Loud Buzzer
 (May be used with a
 UL Listed Class 2
 Power Supply)

SPECIFICATIONS

Voltage: 12-24 VDC or 13-24 VAC (50-60 Hz)
 Current (standby): 45 ma @ 12V, 31 ma @ 24V
 Current (alarm, CM-15): 62 ma @ 12V, 45 ma @ 24V
 Current (standby, CM-15A): 47 ma @ 12V, 32 ma @ 24V
 Current (alarm, CM-15A): 66 ma @ 12V, 46 ma @ 24V
 Size: 4 1/2 X 5 X 1 5/8 inch
 Alarm Relay: 1 Amp, 125V, 30VA
 Trouble Relay: 0.5 Amp, 200V, 10VA
 Buzzer Rating: 85 dBA at 10 Feet
 Shipping Weight: One pound
 Oper. Temp. Range: 32° to 120° F
 Alarm Setting: Per UL 2034 (Oct.98)
 Color: White

Manufactured By:

Macurco
 3946 S. Mariposa Street
 Englewood, CO 80110
 303-781-4062 Fx: 303-761-6640
 www.macurco.com

Distributed By:

TYPICAL CONNECTION OF TWO CM-15/15A's TO AN ALARM CONTROL PANEL

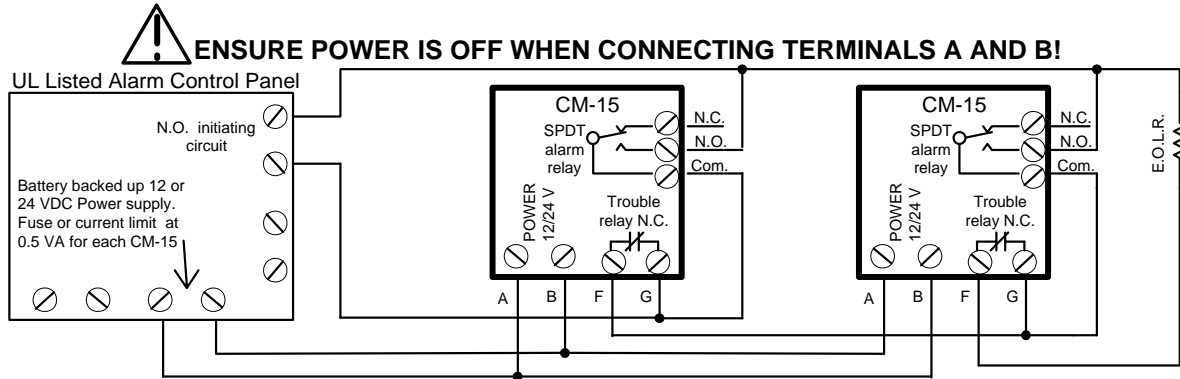

NOTE: CM-15/15A refers to both the CM-15 and CM-15A

1. The CM-15/15A is for use with U.L. Listed Alarm Control Panels (Fire or Fire/Burglar type or Critical Process Management Equipment) that have 12 to 24 Vdc power and 12 to 24 Vdc alarm initiating circuits.
2. The Alarm Control Panel (UL Listed Fire or Fire/Burglar type or Critical Process Management Equipment) must be dedicated to CO detection or have alarm devices that provide a distinctive alarm for carbon monoxide detection. Do not connect the CM-15/15A to Fire Alarm Circuits. For CM-15 installations, a UL Listed audible device must be connected that provides at least 85 dBA sound output.
3. The CM-15/15A is intended for installation in buildings in non-hazardous locations such as residences, retail stores, office buildings, and institutional buildings.
4. The CM-15/15A is NOT intended for use in industrial applications such as refineries, chemical plants, etc. The CM-15/15A is NOT intended for use in parking garages, as the controller of exhaust systems.
5. LOCATION: Place the unit at a level where people breathe: about 5 feet (1.5 meters) above the floor. Mount the CM-15/15A in a vertical position on a wall or column. Do NOT mount the CM-15/15A in a corner.
6. SPACING: Use the same spacing as for smoke detectors-- 30 foot (9 meters) centers, 900 sq. feet (83 sq. meters) per detector.
7. INSTALLATION: In the configuration as normally shipped, the CM-15/15A has a three part case. This allows the unit to mount flush to a wall over a single gang electrical box (not included). If the back cover is removed (remove the two screws inside), the CM-15/15A Gas Detector mounts on a two gang, old work box or a 4 X 4 electrical box, provided by the installer. The CM-15/15A has a terminal strip to connect the cables from the control panel or other device. Access to the terminal strip will be easier if the back cover is removed first.
8. The alarm control panel zone inputs must be terminated with end of line resistors (E.O.L.R.), that are provided with the panel.
9. When using the CM-15/15A with normally closed initiating circuits, use the "N.C." and "COM" alarm relay connections.

